

8-bit 40MSPS RGB 3-channel D/A Converter

Description

The CXD1178Q is an 8-bit high-speed D/A converter for video band use. It has an input/output equivalent to 3 channels of R, G and B. It is suitable for use of digital TV, graphic display, and others.

Features

- Resolution 8-bit
- Maximum conversion speed 40MSPS
- RGB 3-channel input/output
- Differential linearity error $\pm 0.3\text{LSB}$
- Low power consumption 240 mW
(200 Ω load at 2 Vp-p output)
- Single 5 V power supply
- Low glitch noise
- Stand-by function

Structure

Silicon gate CMOS IC

48 pin QFP (Plastic)

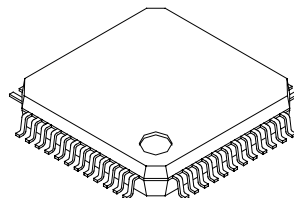
**Absolute Maximum Ratings** ($T_a=25\text{ }^\circ\text{C}$)

- Supply voltage AV_{DD}, DV_{DD} 7 V
- Input voltage (All pins)
 V_{IN} $V_{DD}+0.5$ to $V_{SS}-0.5$ V
- Output current (Every each channel)
 I_{OUT} 0 to 15 mA
- Storage temperature T_{stg} -55 to $+150$ $^\circ\text{C}$

Recommended Operating Conditions

- Supply voltage AV_{DD}, AV_{SS} 4.75 to 5.25 V
 DV_{DD}, DV_{SS} 4.75 to 5.25 V
- Reference input voltage
 V_{REF} 2.0 V
- Clock pulse width
 $TPW1, TPW0$ 11.2 ns (min.) to 1.1 μs (max.)
- Operating temperature
 T_{opr} -40 to $+85$ $^\circ\text{C}$

Sony reserves the right to change products and specifications without prior notice. This information does not convey any license by any implication or otherwise under any patents or other right. Application circuits shown, if any, are typical examples illustrating the operation of the devices. Sony cannot assume responsibility for any problems arising out of the use of these circuits.

Block Diagram

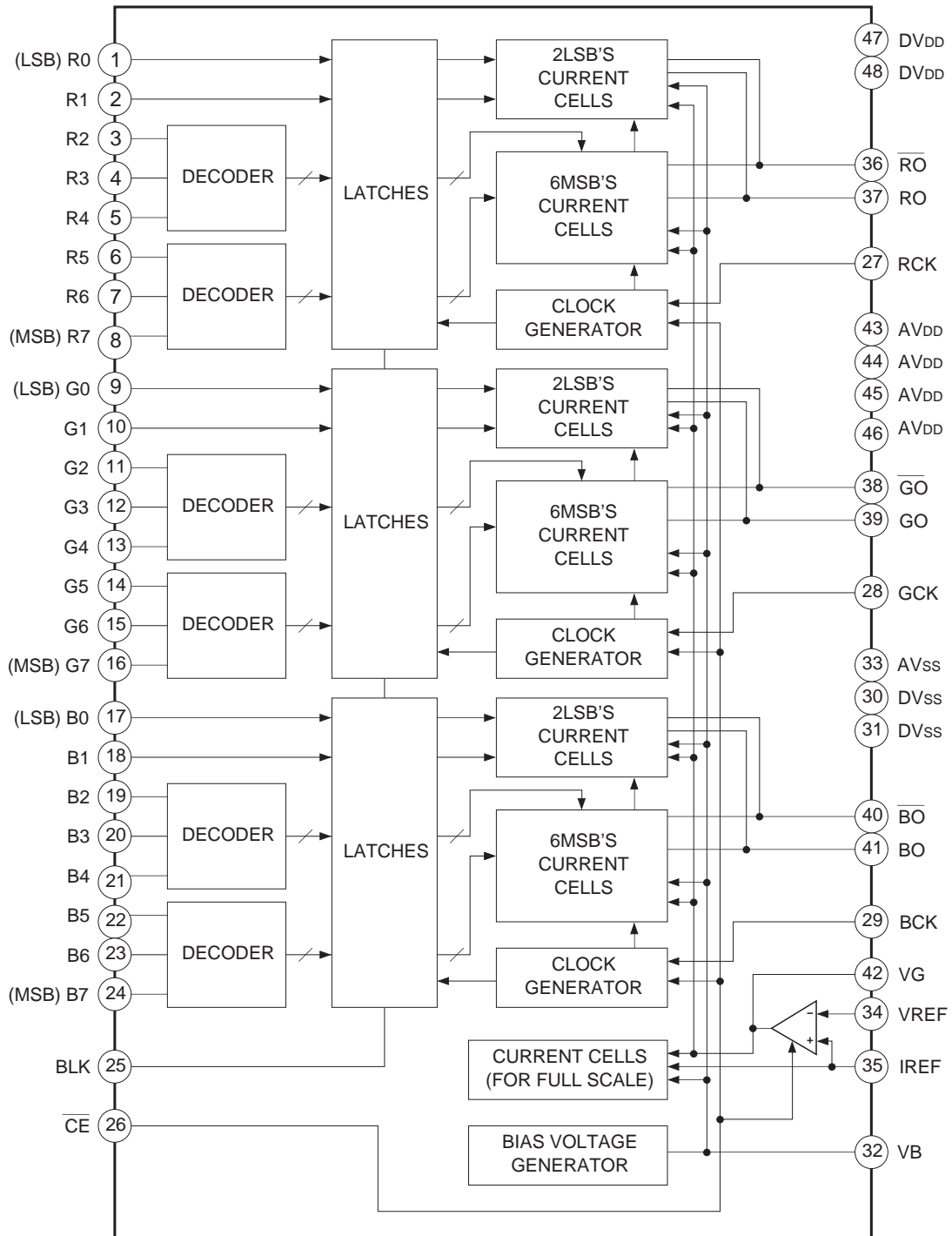

Pin Configuration

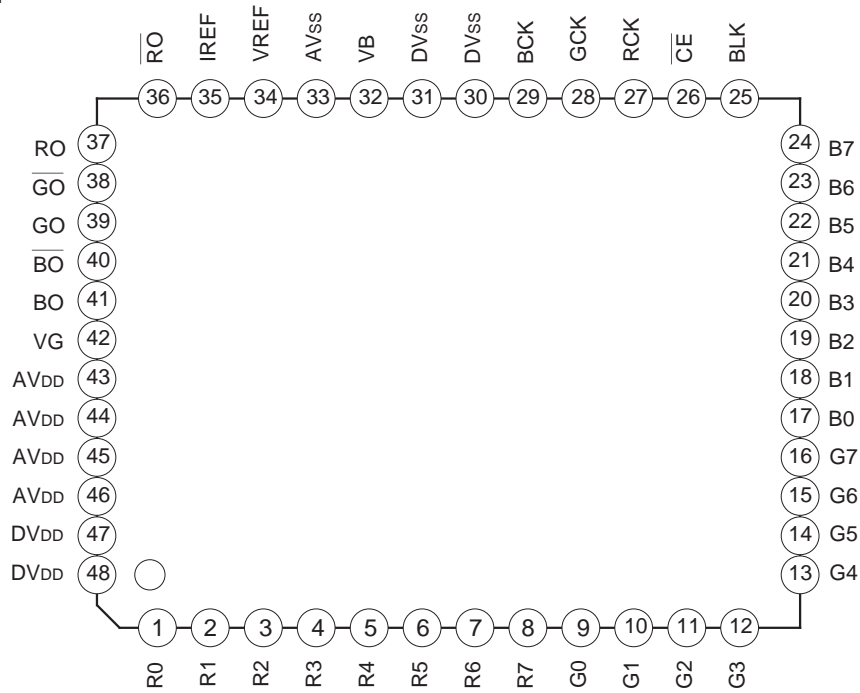

Pin Description and I/O Pins Equivalent Circuit

Pin No.	Symbol	I/O	Equivalent circuit	Description
1 to 8	R0 to R7	I		Digital input R0 (LSB) to R7 (MSB) G0 (LSB) to G7 (MSB) B0 (LSB) to B7 (MSB)
9 to 16	G0 to G7			
17 to 24	B0 to B7			
25	BLK	I		Blanking input. No signal at "H" (Output 0 V). Output condition at "L".
32	VB	O		Connect a capacitor of about 0.1 μF.

Pin No.	Symbol	I/O	Equivalent circuit	Description
27	RCK	I		Clock input.
28	GCK			
29	BCK			
30, 31	DVSS	—		Digital GND
33	AVSS	—		Analog GND
26	\overline{CE}	I		Chip enable input. No signal (Output 0 V) at "H" and minimizes power consumption.
35	IREF	O		Reference current output. Connect a resistance 16 times "16R _{OUT} " that of output resistance value "R _{OUT} ".
34	VREF	I		Reference voltage input. Set full scale output value.
42	VG	O		Connect a capacitor of about 0.1 μ F.
43 to 46	AVDD	—		Analog VDD

Pin No.	Symbol	I/O	Equivalent circuit	Description
37	RO	O		Current output pins. Voltage output can be obtained by connecting a resistance.
39	GO			
41	BO			
36	\overline{RO}			
38	\overline{GO}			
40	\overline{BO}			
47, 48	DV _{DD}	—		Digital V _{DD}

(f_{CLK}=40 MHz, AV_{DD}=DV_{DD}=5 V, R_{OUT}=200 Ω, V_{REF}=2.0 V, Ta=25 °C)

Item	Symbol	Measurement conditions	Min.	Typ.	Max.	Unit	
Resolution	n			8		bit	
Conversion speed	f _{CLK}	AV _{DD} =DV _{DD} =4.75 to 5.25 V Ta=-40 to 85 °C	0.5		40	MSPS	
Integral non-linearity error	EL	Endpoint	-2.5		2.5	LSB	
Differential non-linearity error	ED		-0.3		0.3	LSB	
Output full-scale voltage	V _{FS}		1.8	2.0	2.2	V	
Output full-scale ratio *1	F _{SR}		0	1.5	3.0	%	
Output full-scale current	I _{FS}			1.0	15	mA	
Output offset voltage	V _{OS}	When "00000000" data input			1	mV	
Glitch energy	GE	R _{OUT} =75 Ω		30		pV-s	
Crosstalk	CT	When 1 MHz sine wave input		57		dB	
Supply current	I _{DD}	14.3MHz color bar		CE = "L"	42	48	mA
	I _{STB}	data input		CE = "H"	1	2	
Analog input resistance	R _{IN}	V _{REF}	1			MΩ	
Input capacitance	C _I				9	pF	
Digital input voltage	V _{IH}	AV _{DD} =DV _{DD} =4.75 to 5.25 V	2.4			V	
	V _{IL}	Ta=-20 to 75 °C			0.8		
Digital input current	I _{IH}	AV _{DD} =DV _{DD} =4.75 to 5.25 V	-5		5	μA	
	I _{IL}	Ta=-20 to 75 °C					
Setup time	t _s	R _{OUT} =75 Ω	5			ns	
Hold time	t _h	R _{OUT} =75 Ω	10			ns	
Propagation delay time	t _{PD}			10		ns	
CE enable time *2	t _E	CE = H→L		1.8	4	ms	
CE disable time *2	t _D	CE = L→H		1.8	4	ms	

*1 Full-scale output ratio = $\left| \frac{\text{Full-scale voltage of channel}}{\text{Average of the full-scale voltage of the channels}} - 1 \right| \times 100 (\%)$

*2 When the external capacitor for the VG pin is 0.1 μF.

Electrical Characteristics Test Circuit

Analog Input Resistance } Test Circuit
 Digital Input Current }

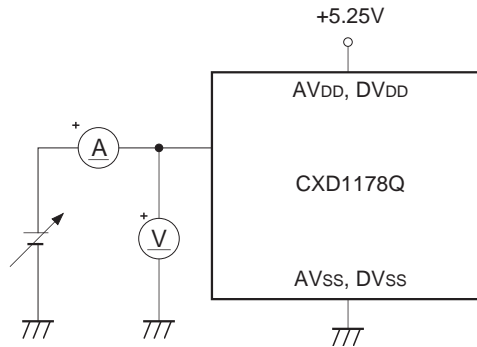

Maximum Conversion Velocity Test Circuit

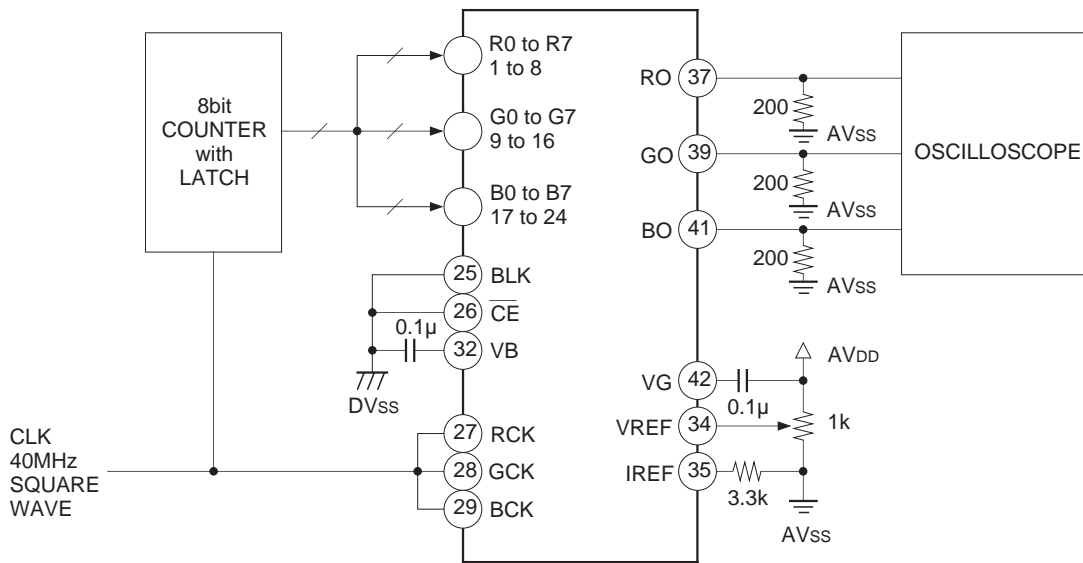

Setup Time
Hold Time
Glitch Energy

} Test Circuit

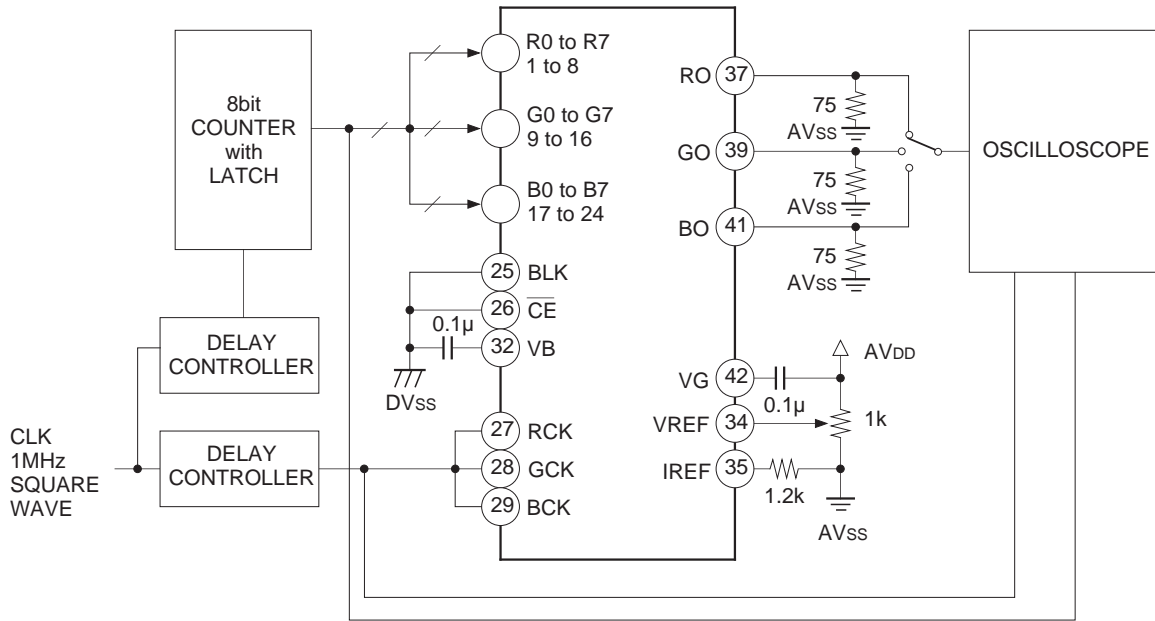

Crosstalk Test Circuit

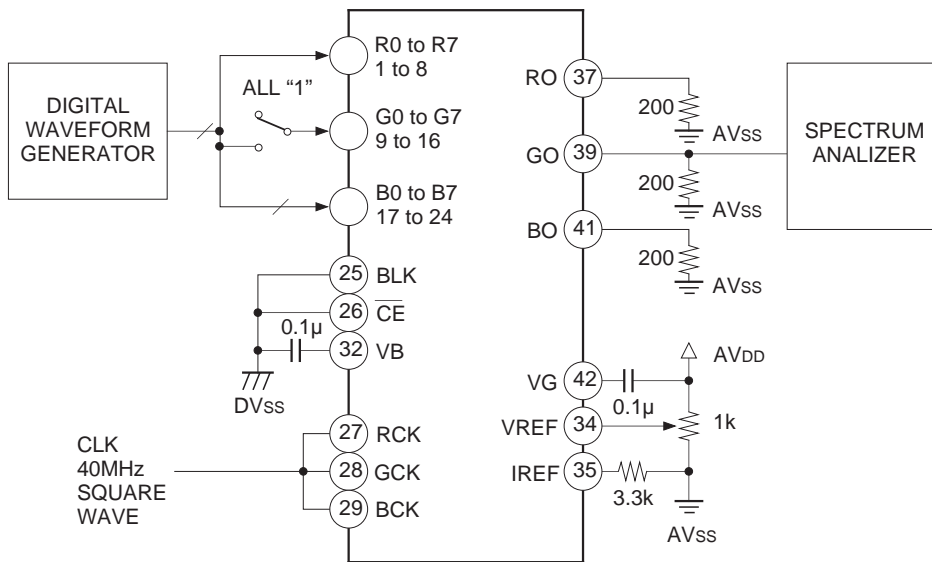

DC Characteristics Test Circuit

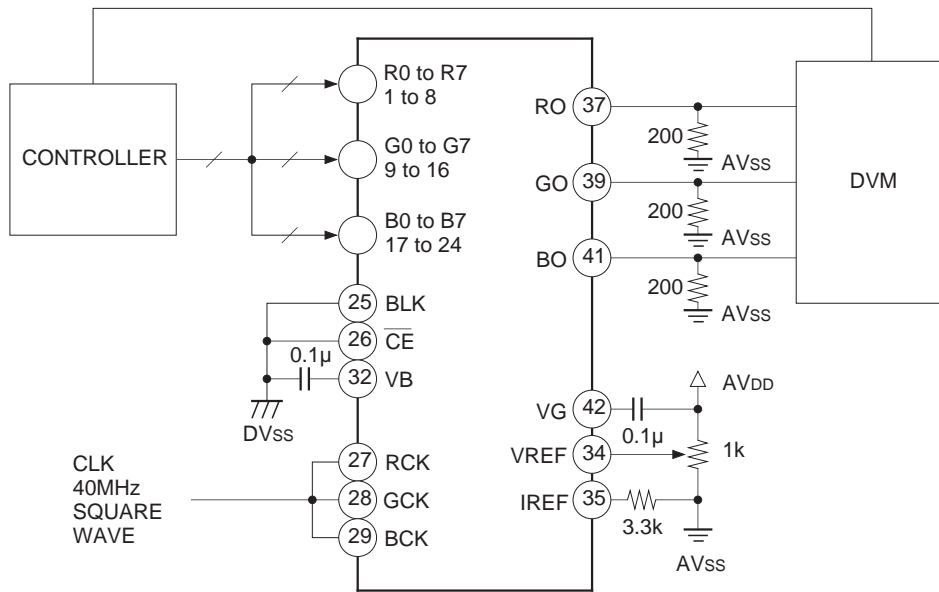

Propagation Delay Time Test Circuit

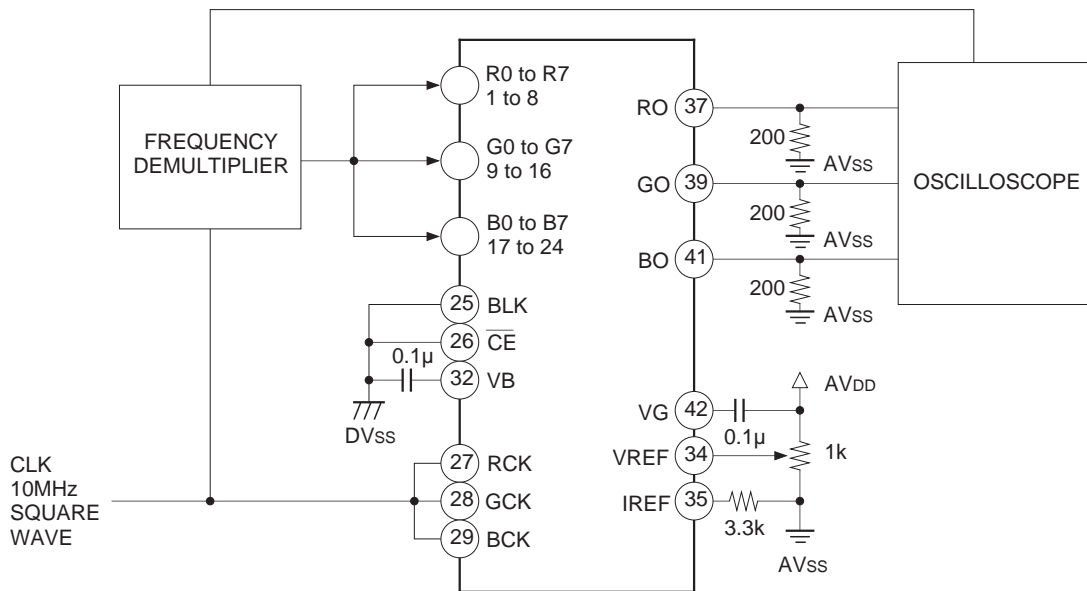

Description of Operation

Timing Chart

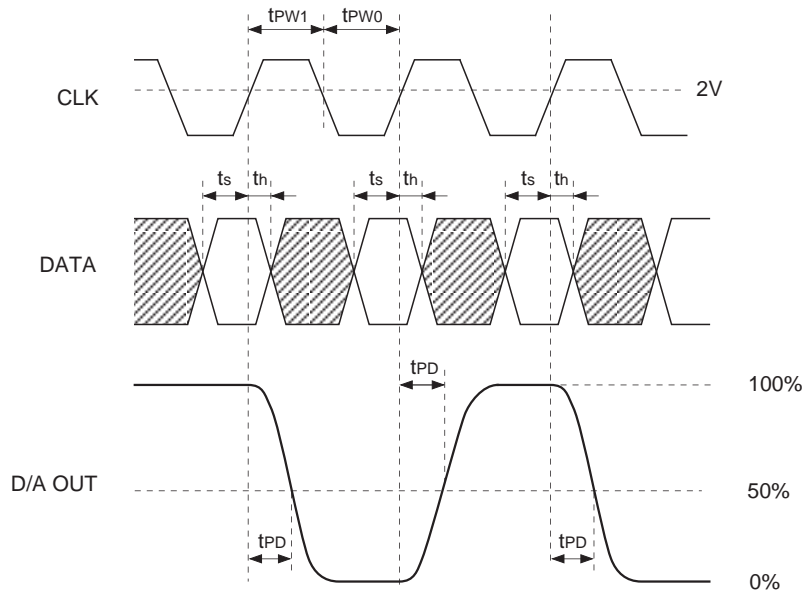

I/O Chart (when full scale output voltage at 2.00 V)

Input code		Output voltage
MSB	LSB	
1	1 1 1 1 1 1 1 1	2.0 V
	:	
1	0 0 0 0 0 0 0 0	1.0 V
	:	
0	0 0 0 0 0 0 0 0	0 V

Application Circuit

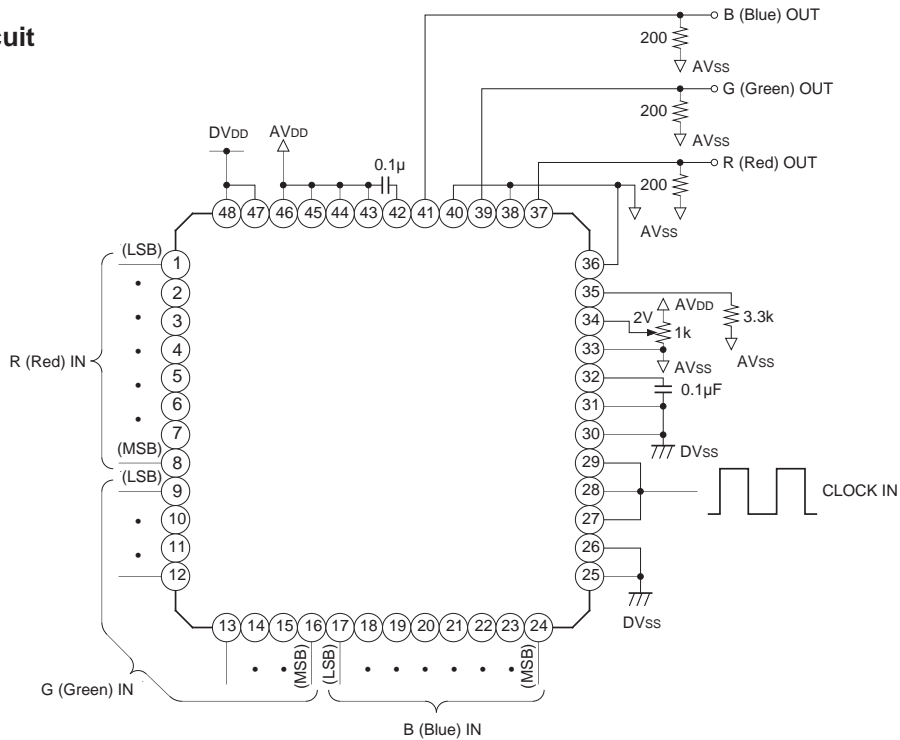

Application circuits shown are typical examples illustrating the operation of the devices. Sony cannot assume responsibility for any problems arising out of the use of these circuits or for any infringement of third party patent and other right due to same.

Notes on Operation

- How to select the output resistance

The CXD1178Q is a D/A converter of the current output type. To obtain the output voltage connect the resistance to current output pins (RO, GO and BO). For specifications we have;

Output full scale voltage $V_{FS}=1.8$ to 2.2 [V]

Output full scale current $I_{FS}=\text{less than } 15$ [mA]

Calculate the output resistance value from the relation of $V_{FS}=I_{FS} \times R_{OUT}$. Also, 16 times resistance of the output resistance is connected to reference current pin IREF. In some cases, however, this turns out to be a value that does not actually exist. In such a case a value close to it can be used as a substitute.

Here please note that V_{FS} becomes

$$V_{FS}=V_{REF} \times 16R_{OUT}/R_{IR}.$$

V_{REF} is the voltage set at the VREF pin and R_{OUT} is the resistance connected to current output pins (RO, GO and BO) while R_{IR} is connected to IREF.

Increasing the resistance value can curb power consumption. On the other hand glitch energy and data settling time will inversely increase. Set the most suitable value according to the desired application.

- Phase relation between data and clock

To obtain the expected performance as a D/A converter, it is necessary to set properly the phase relation between data and clock applied from the exterior. Be sure to satisfy the provisions of the setup time (t_s) and hold time (t_H) as stipulated in the Electrical Characteristics.

- Power supply and ground

To reduce noise effects separate analog and digital systems in the device periphery. For power supply pins, both digital and analog, bypass respective grounds by using a ceramic capacitor of about $0.1 \mu\text{F}$, as close as possible to the pin.

- Latch up

Analog and digital power supply have to be common at the PCB power supply source. This is to prevent latch up due to voltage difference between AV_{DD} and DV_{DD} pins when power supply is turned ON.

- On inverted current output pins

The \overline{RO} , \overline{GO} and \overline{BO} are the inverted current output terminal as described in the Pin Description.

The sums shown below become the constant value for any input data.

a) The sum of the currents output from the \overline{RO} and RO pins.

b) The sum of the currents output from the \overline{GO} and GO pins.

c) The sum of the currents output from the \overline{BO} and BO pins.

However, the output current from the \overline{RO} , \overline{GO} and \overline{BO} pins is not guaranteed of its performances such as linearity errors, etc.

- On output full-scale voltage

When the output full-scale voltage is used without adjustment in the application that uses the RGB signal, the color balance may be broke.

Latch Up Prevention

The CXD1178Q is a CMOS IC which required latch up precautions. Latch up is mainly generated by the lag in the voltage rising time of AV_{DD} (Pins 43 to 46) and DV_{DD} (Pins 47 and 48), when power supply is ON.

1. Correct usage

a. When analog and digital supplies are from different sources

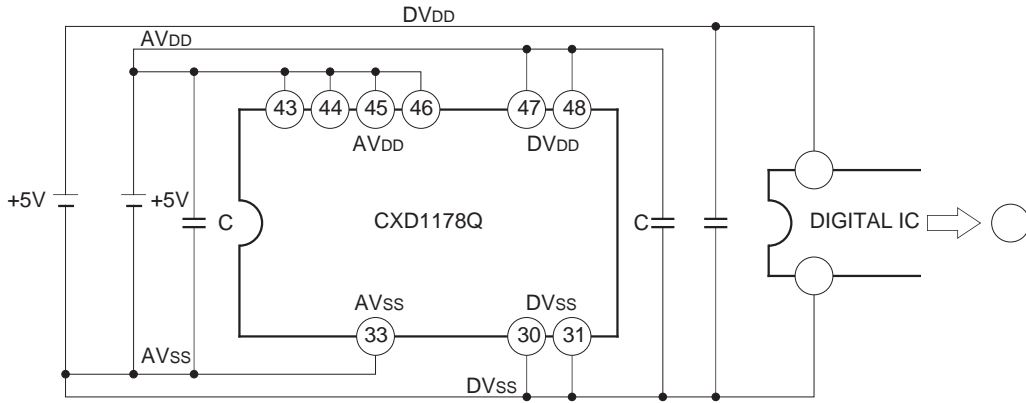

b. When analog and digital supplies are from a common source

(i)

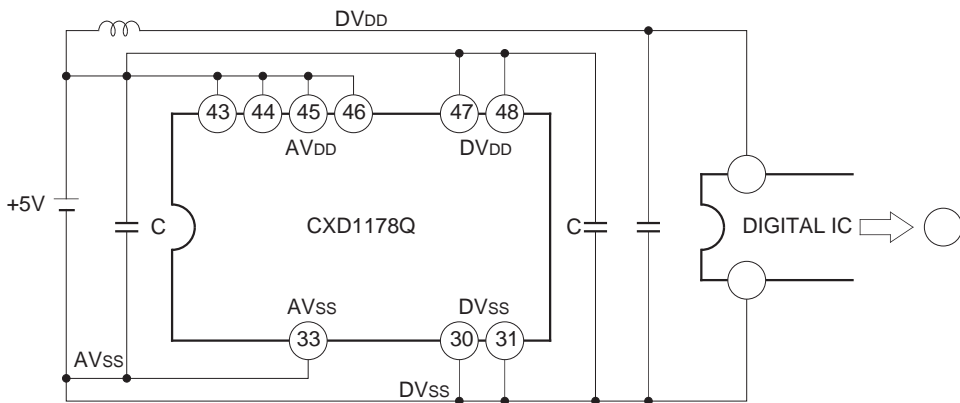

(ii)

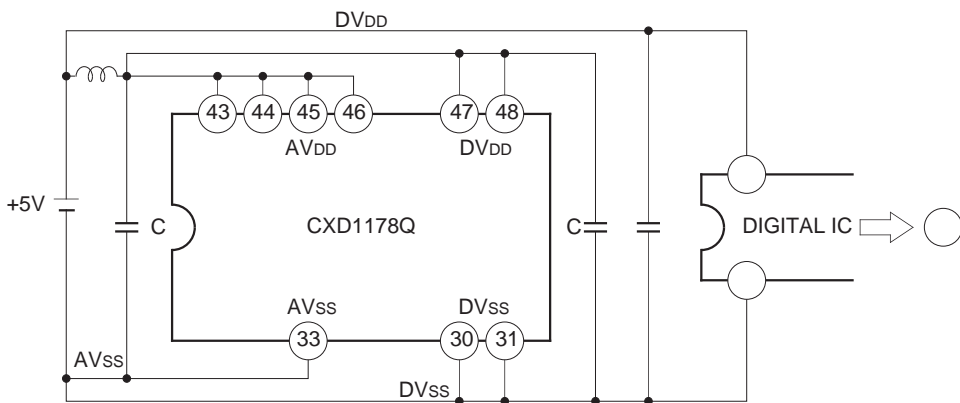

2. Example when latch up easily occurs

a. When analog and digital supplies are from different sources

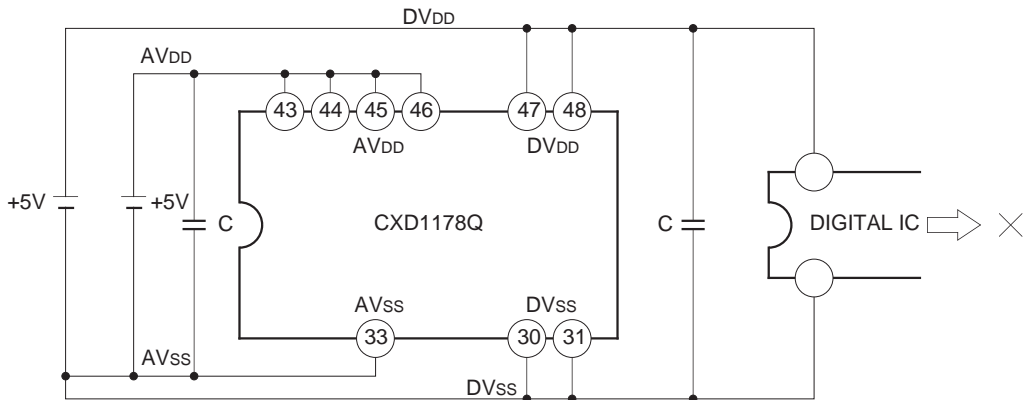

b. When analog and digital supplies are from common source

(i)

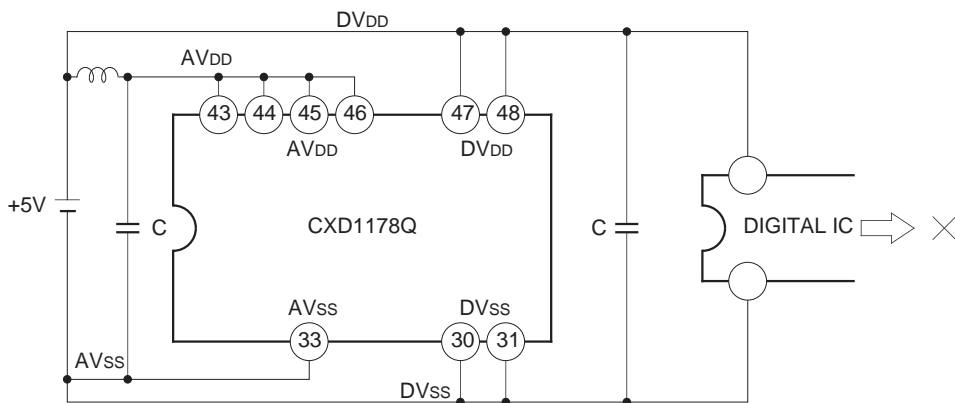

(ii)

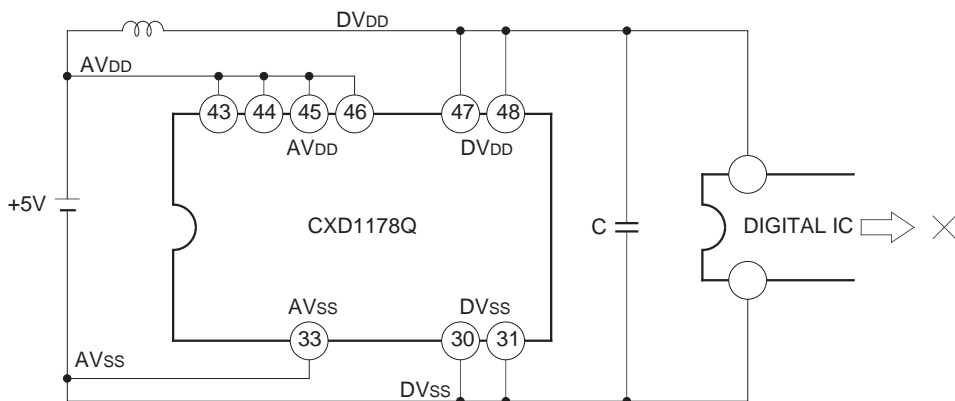

Example of Representative Characteristics

Output full scale voltage vs. Reference voltage

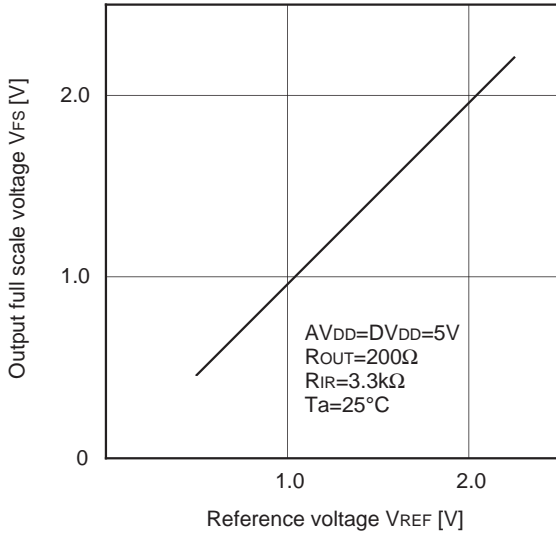

Glitch energy vs. Output resistance

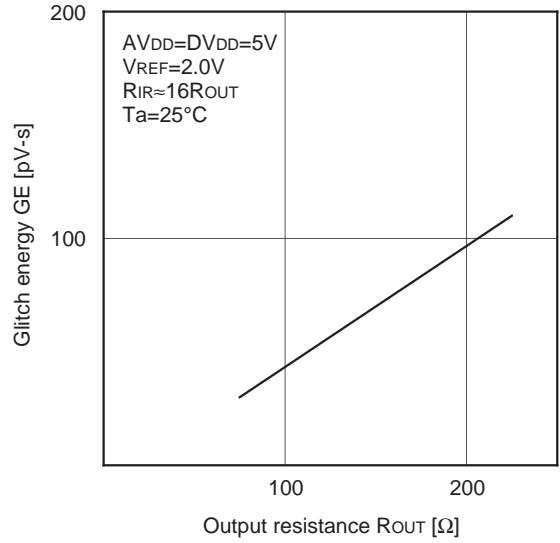

Output full scale voltage vs. Ambient temperature

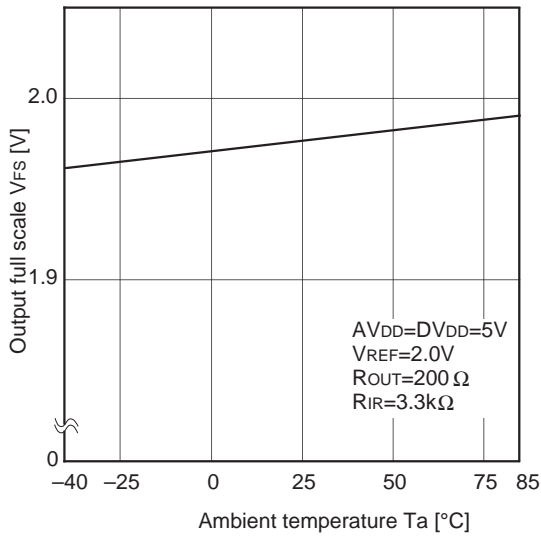

Crosstalk vs. Output frequency

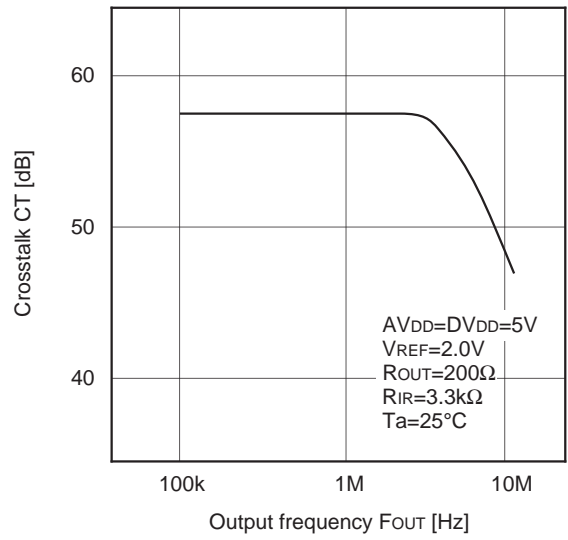

Package Outline Unit : mm

48PIN QFP (PLASTIC)

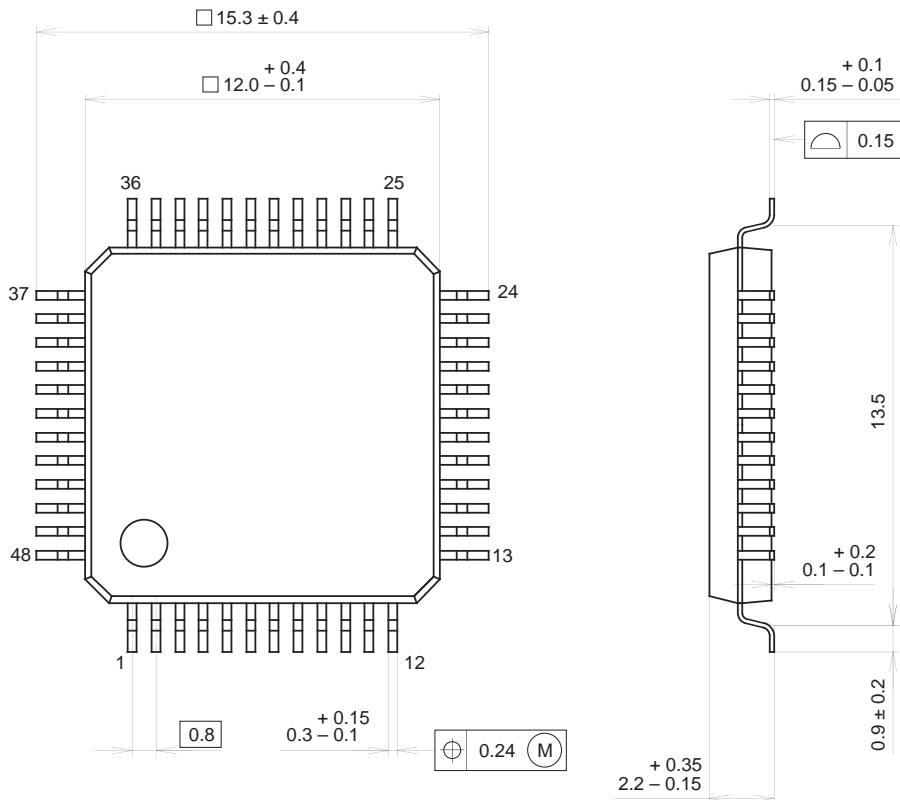

PACKAGE STRUCTURE

SONY CODE	QFP-48P-L04
EIAJ CODE	QFP048-P-1212
JEDEC CODE	_____

PACKAGE MATERIAL	EPOXY RESIN
LEAD TREATMENT	SOLDER / PALLADIUM PLATING
LEAD MATERIAL	42/COPPER ALLOY
PACKAGE MASS	0.7g